

MODEL NUMBER: DL-T1-A-1C-1-OBJ-MB	FIXTURE TYPE: 1/4"=1"	SCALE: 1/4"=1"	FILE NUMBER: Product\DownLights\DL-OBJECTLITE	DATE: 3/3/05	NO.	REVISIONS DESCRIPTION	BY	DATE
PROJECT NAME:	APPROX. WEIGHT: 6lbs\2.7Kg	DRAWN BY: D.G.A.	CK'D BY: B.G.3/05	FIXTURE DESCRIPTION: 1 LAMP MR16 RECESSED OBJECT LIGHT	2	UPDATED PER B.O.M. DEPT.	D.A.	1/24/06

SECTIONED SIDE VIEW

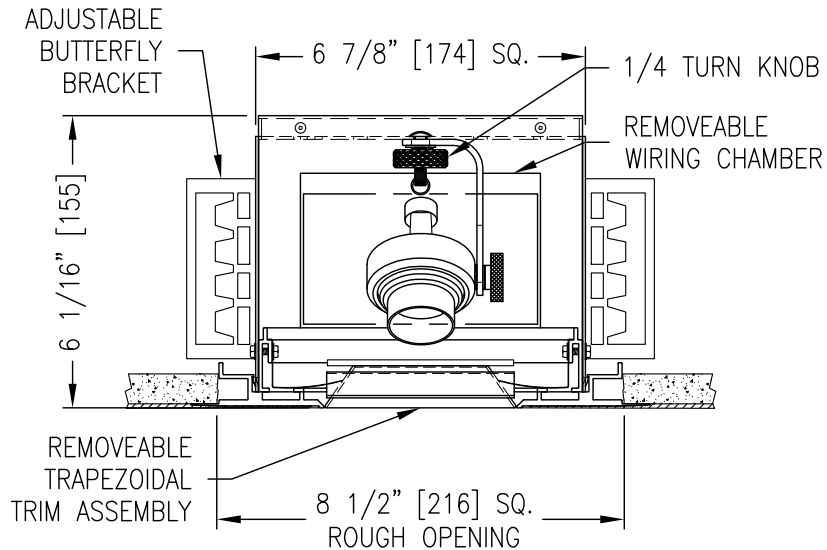

SECTIONED END VIEW

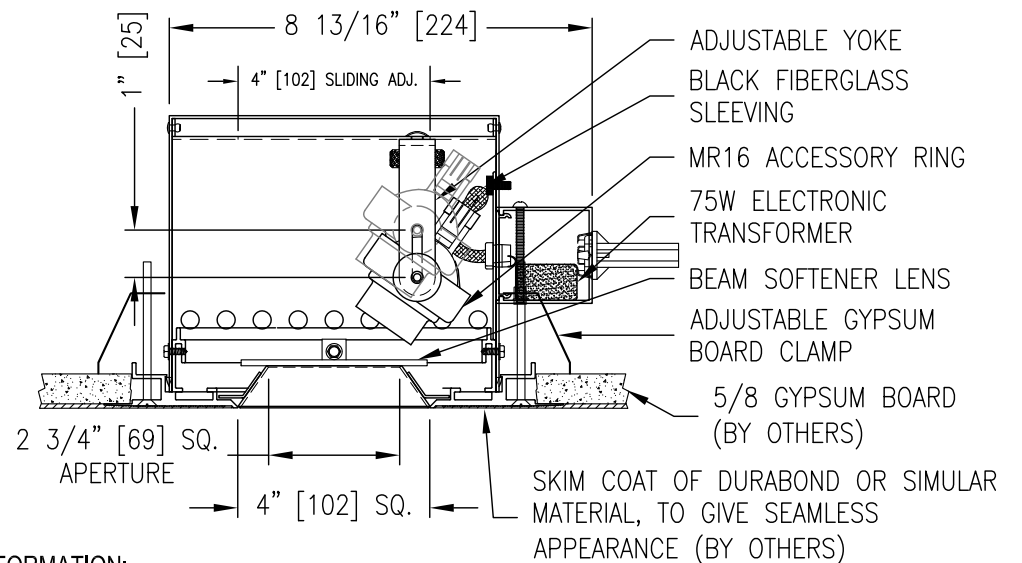

BOTTOM VIEW

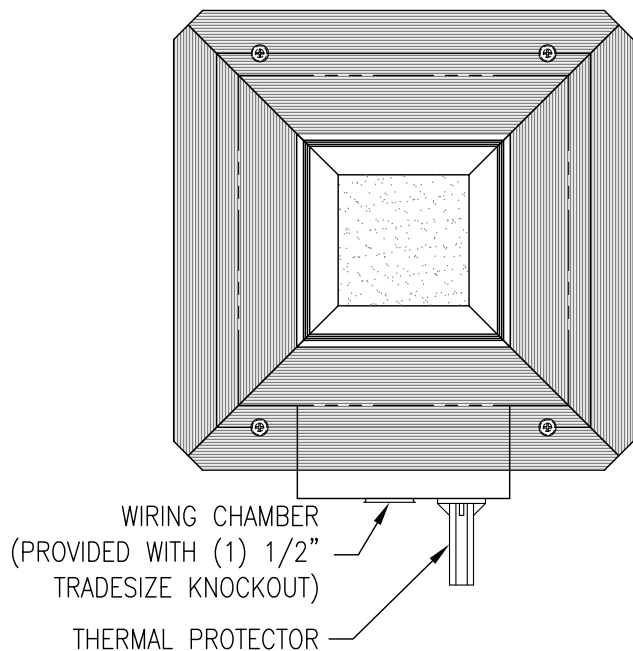

INSTALLATION INFORMATION:

ETL LISTED AS A NON-IC FIXTURE
DO NOT INSTALL INSULATION WITHIN 3" (76mm) OF ANY PART OF THIS FIXTURE. DO NOT BLOCK VENT HOLES ON FIXTURE. MAXIMUM AMBIENT TEMPERATURE NOT TO EXCEED 35°C.

INPUT REQUIREMENTS:

(1) MR16 50 WATT MAX.
277V/60Hz/.27 AMPS

ACCESSORIES: (included)

61509-OMB FULL SNOOT
OL-5x55-a OPTICAL LENS

DIMMING INFORMATION:

THE MANUFACTURER OF THE ELECTRONIC TRANSFORMERS USED IN OUR INTEGRALLY TRANSFORMED LIGHTING FIXTURES SAYS THAT THE TRANSFORMERS ARE SUITABLE FOR "ALL LEADING AND TRAILING EDGE DIMMER SYSTEMS". WHILE WE STAND BEHIND THIS STATEMENT, WE WILL NOT BE RESPONSIBLE FOR ANY NOISE OR OTHER COMPATIBILITY ISSUES WITH ANY DIMMING OR CONTROL SYSTEM AND STRONGLY RECOMMEND THAT THE UNITS BE TESTED BY THE CUSTOMER TO ENSURE THEIR PERFORMANCE SATISFACTION. LITELAB WILL FURNISH UNITS FOR TEST AT THE CUSTOMER'S REQUEST.

ACCESSORIES: (ordered separately)

NONE

LAMP SPEC: (ordered separately)

MR16 50 WATT MAX.

FINISH:

SLOT INTERIOR: MATTE BLACK

FIXTURE: MATTE BLACK

TRIM: WHITE