

## Surface

## Clips 1

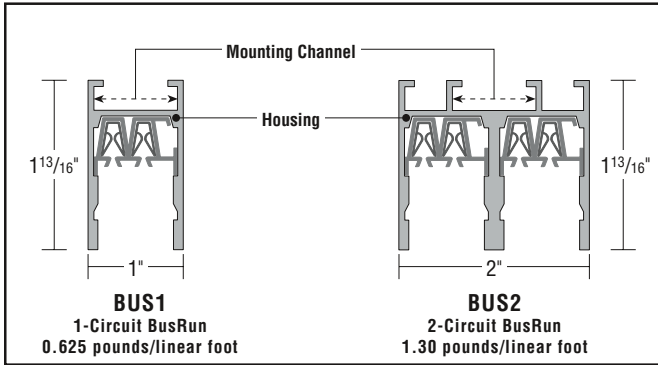

**Surface Joiner**



**BusRun Cross-Sections**

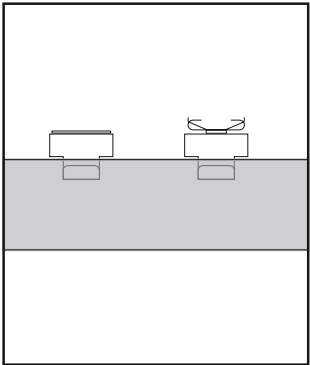

**Mounting Hardware**  
(ordered separately)

## INSTALLATION GUIDE

### Typical Layouts

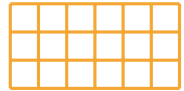
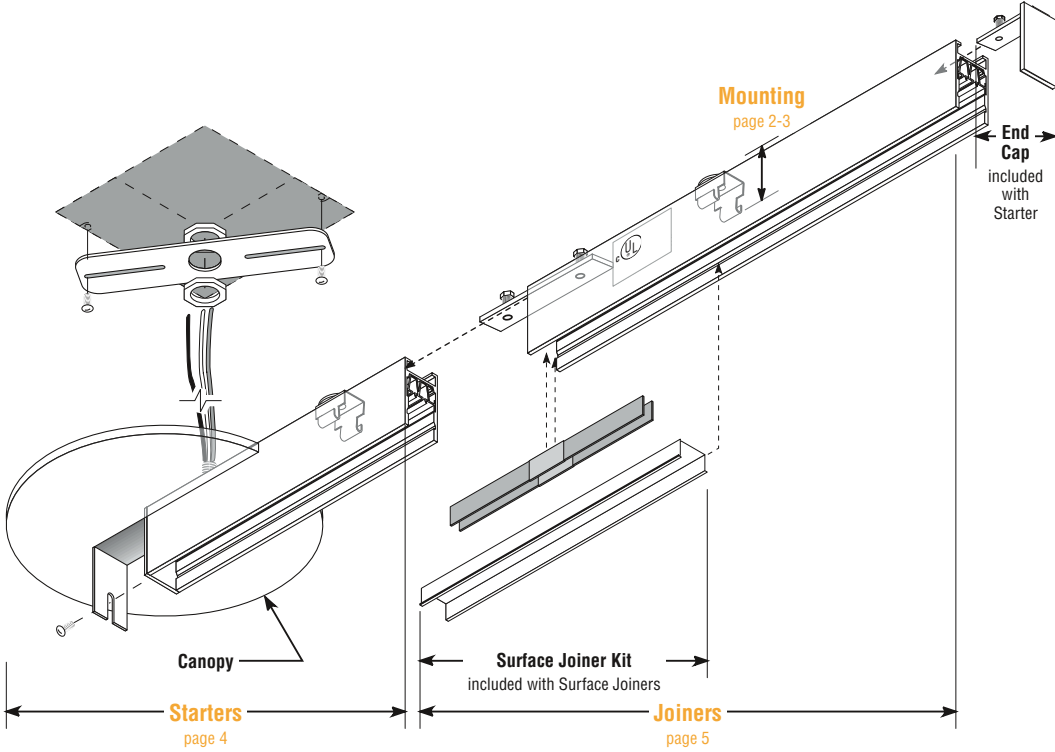

**Grids**



**Rows**



**Patterns**



**Pathways**



## S Mounting Point Rules

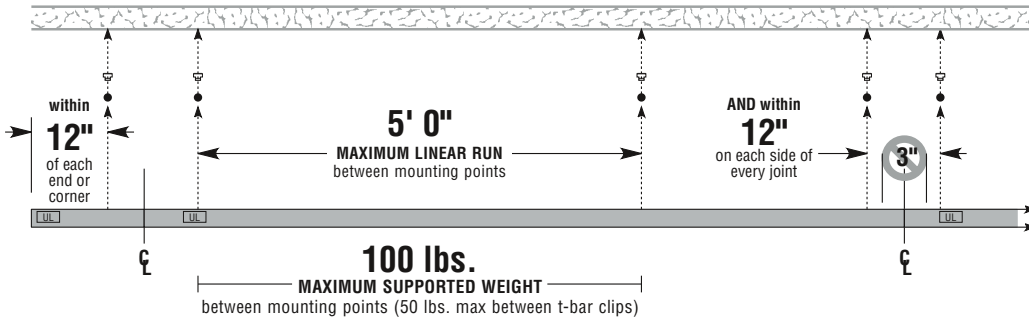

- 12"** • A mounting-point must be provided within 12" of every end or corner of the BusRun layout.
- 5' 0"** • Maximum distance between mounting-points cannot exceed 5 linear feet of 'S' BusRun busway.
- 12"** • Mounting points must be provided within twelve inches on each side of every joint between pieces.
- 3"** • Mounting points cannot be made within 3" on either side of the centerline at joints.
- 100 lbs** • BusRun busway and mounting hardware are rated for a total supported weight up to 100 pounds between mounting points (50 pounds maximum between t-bar clips).
  - If the total supported weight between mounting points *exceeds* maximum, shorten the distance between them to comply with maximum (as shown below).
- 40 lbs** • The BusRun fitting is rated for 40 pounds (maximum) static, vertical load.
  - Only BusRun fittings and/or BusRun supplements may be mounted directly to BusRun busway.

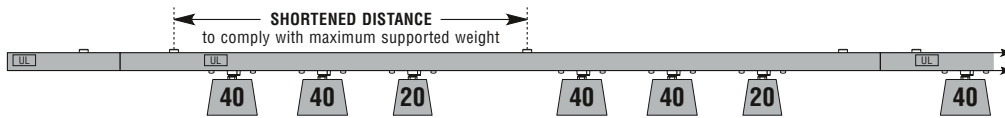

## Support

Structure and everything from Structure to BusRun Mounting Hardware must be engineered and installed so as to properly support the entire suspended weight.

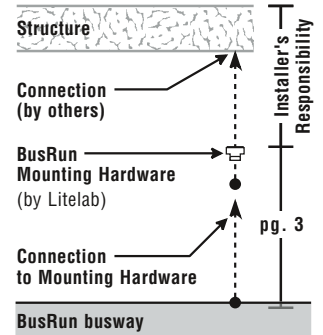

**Weight of 'S' BusRun busway**  
 1-circuit – 0.625 lb per running foot  
 2-circuit – 1.30 lb per running foot  
 (not including connected weight)

## S Mounting Point Examples

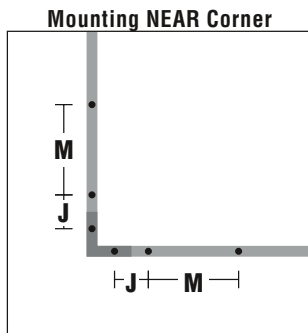

At least one mounting point must be located within 12" of every BusRun corner. Surface-mount hardware cannot be properly installed in corners.

Mounting points must be provided within 12" on both sides of every seam between the intercept and the Joiner to which it is attached.

Distance to the next mounting point on each side cannot exceed **Maximum**.

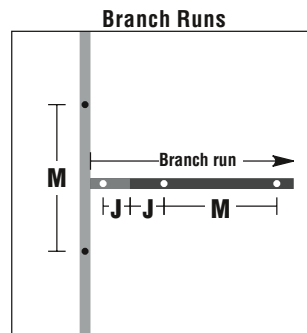
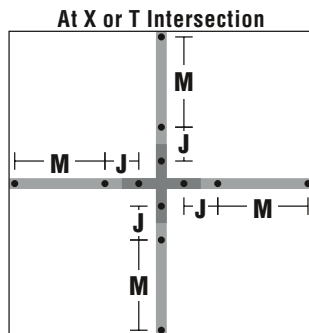

Branch runs must have a mounting point on the BranchStarter within 12" on both sides of every joint, not more than **Maximum** between any two points, and within 12" of the end of the run.

## KEY

- M** Maximum distance supporting 100 pounds, not to exceed 5 feet as measured along centerline of the BusRun
- J** Mounting points within 12" on both sides of every joint.
  - Mounting point
  - S BusRun – Joiner lengths
  - S BusRun – L, T, or X Intercept
  - as labeled where used

## S Mounting Hardware

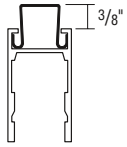

BusRun Mounting Hardware

BusRun busway

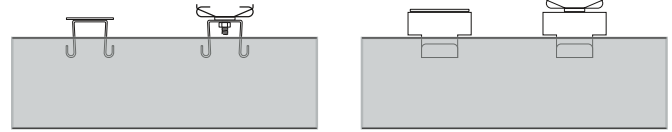

### 1 • Assemble & Secure Hardware to Ceiling

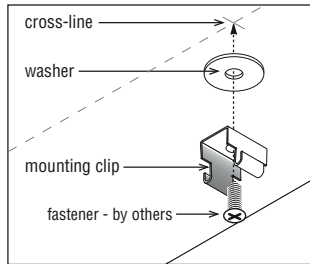

#### Fasten Surface Clips

Snap a chalk line on the ceiling to indicate centerline of BusRun, then make cross-lines to indicate mounting points. Center holes in washer and mounting clip over cross-lines. Secure both to ceiling with fasteners suitable for the ceiling type and mounting-point requirements defined on page 2.

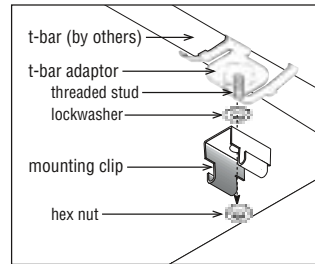

#### Fasten T-Bar Clips

Put lockwasher, mounting clip and hex nut on threaded stud of t-bar adaptor. Clip assembly onto t-bar ceiling in compliance with mounting-point requirements defined on page 2, and below. After BusRun has been mounted to hardware (see right) go back and ensure tightness of hexnuts on threaded studs.

**⚠ T-bar adaptors are rated for 50 pounds between mounting points, not 100. Increase the number of mounting points to reduce supported weight between them.**

### 2 • Mount BusRun to Hardware

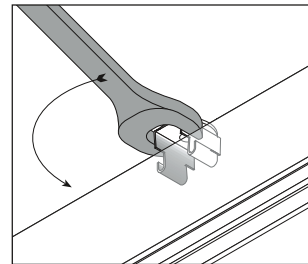

#### Position & Rotate Hardware

Position BusRun below hangers with rolled ends of hangers oriented to mounting channel as shown above. Rotate hangers 90° using a 5/8" open-end wrench, as shown. Clip may distort during rotation, but will spring back to original shape when correctly installed.

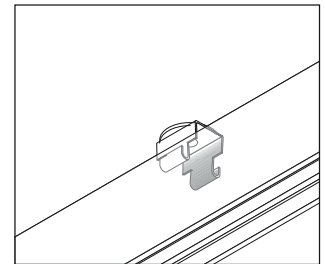

#### Fully-Installed

After rotation, rolled ends of hangers fit under flanges of the BusRun mounting channel. Tug BusRun to check that both sides of the mounting clip are engaged. If a mounting clip must be removed, pinch clip slightly with pliers or insert screwdriver into opening of clip and rotate 90°.

## Plug-Ins on S BusRun

The BusRun fitting is rated for up to 40 pounds static, vertical load.

Only BusRun fittings and/or BusRun supplements may be mounted directly to BusRun busway.

When mounting lighting fixtures by others to BusRun PowerTaps, or signage to BusRun SignHangers, the total weight per item cannot exceed 40 pounds static, vertical load.

Bridges PLUS the weight mounted to them cannot exceed 40 pounds total.

#### Bridge Example

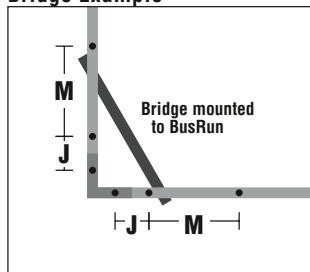

Weight of Bridge and plug-ins mounted to it cannot exceed 40 pounds and must be included in the 100 lb maximum between BusRun mounting points.

## Lighting, Power & Support, by Litelab

#### Lighting Fixtures



#### SignHangers



for signs

#### PowerDown Boxes

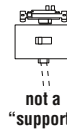

not a "support" for non-lighting devices by others

#### PowerAcross Bridges

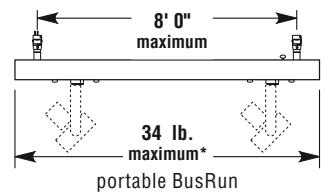

\*all weight ratings are based on static, vertical load.

## PowerTaps for Lighting by Others (consult)

#### Decorative PowerTaps

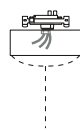

#### Hi-Bay PowerTaps

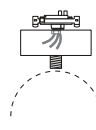

#### Hi-Bay Bracket PowerTaps

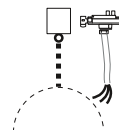

#### Fluorescent Bracket PowerTaps

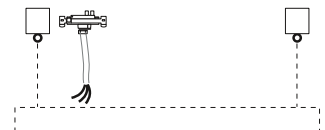

## S Starters

### Hardwired maximum 60A

supplied with End Cap for end of run

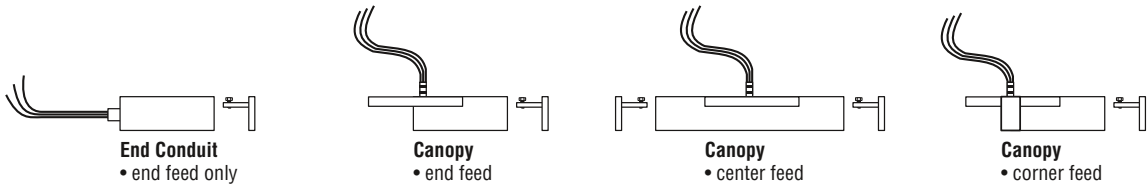

### Connections

Item	1-Circuit	2-Circuit
<b>End Conduit – 30" leads standard</b>		
• coupling	for 1/2" NPSM.	for 3/4" NPSM
<b>Canopy – 9" leads</b>		
• Canopy	6 3/4" dia.	6 3/4" dia.
• j-box, by others	4 11/16" square x 2 1/8" deep or equivalent volume	4 11/16" sq. x 2 1/8" d. with 1 1/2" extension. or equivalent volume
<b>Lead Wire</b>		
• supplied	1 each #8 AWG hot neutral and ground	2 each #8 AWG hot neutral and ground
<p>BusRun Starters do <u>not</u> have screw terminals. Leads must be factory-fitted in standard (above) or custom lengths (specified at time of order). Field-connections to extend lead length must be made in an accessible junction box.</p> <p>BusRun Starters are a UL listed factory assembly with #8 AWG leads. As such, they are not subject to the same NEC sizing requirements as the building wiring (feeds) brought to them.</p>		
<b>Feed Wire</b>		
• by others	#6 AWG rated 90° C.	#6 AWG rated 90° C.
<p>Smaller wire may be used (as allowed) for feeds less than 60 amps. Refer to appropriate building/electrical codes.</p>		

### Maximum Feed

Max Voltage	Max. Current
300 V.A.C. max.	60 amps max.

### Line-Voltage Loads

120 VAC		277 VAC		CURRENT
Max. Load	Max. Run	Max. Load	Max. Run	Feed Breaker
7,200 watts	260 feet	16,620 watts	595 feet	60-Amp
6,000 watts	310 feet	13,850 watts	715 feet	50-Amp
4,800 watts	390 feet	11,080 watts	890 feet	40-Amp
3,600 watts	516 feet	8,310 watts	1,194 feet	30-Amp
2,400 watts	780 feet	5,540 watts	1,790 feet	20-Amp

Ratings for Maximum Load and Maximum Run were calculated to produce no more than 5% voltage drop, based on an evenly distributed load.

### Low-Voltage Loads

**Do NOT proceed as above!**  
**Refer to separate Instructions and Ratings for Low-Voltage (12V) BusRun.**  
 If not enclosed, contact customer service at 1-800-238-4120.

## S Starters

### BranchBus maximum 20A

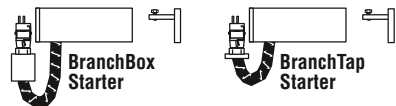

### BranchBus Connections

Item	Description
<b>Feed</b>	Plug-in fitter and stainless steel-sheathed cable provide 20-amp fused power from 60-amp (max) main run.
<b>Mounting</b>	Mounting hardware (specified separately) holds BranchBus Starter against main run from which it gets power (diagrams at right). BranchBus Starters and connected Joiners <u>must</u> be secured to structure according to same Mounting Rules as main runs.

### BranchBus Loads

Item	Fuse	Voltage	Max Load	Max Run
<b>BranchBox Starter fused in box</b>	20A	120V	2,400 watts	780 feet
	20A	277V	5,540 watts	1,790 feet
<b>BranchTap Starter* fused in fitting</b>	20A	120V	2,400 watts	25 feet
	20A	277V	5,540 watts	25 feet

\* As a tap, the maximum length of run using this product can range from 25 - 50 feet. Consult Articles 240-21 and 364-11 of the National Electrical Code.

### Assembly & Mounting

BranchBus Starters must be mounted to the ceiling independently of the main run from which they get power.

Joiners used for branch runs are the same as those used in main runs. Follow the instructions for connecting and mounting, as detailed within the pages of this book.

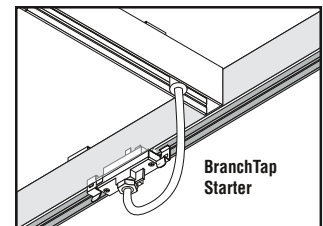
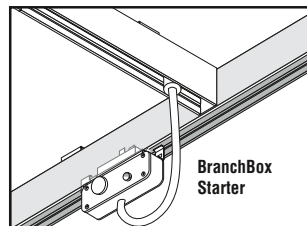
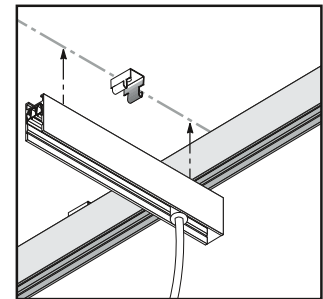

After Joiners and End Cap have been added to complete the branch run, plug fitting from Branch starter into main run.

## S Joiners

for use with Starters  
(hardwired  
or BranchBus)

includes items shown,  
mounting hardware  
specified separately



### Basic Steps of Joining BusRun Pieces

#### 1 • Verify Gap at Ends

BusRun is supplied with copper busbars cut 5/8" back from the open ends so joints can be made between pieces. Although the busbars in Starters and Intercepts are glued in place, those in Joiners are not. This allows standard Joiner lengths to be field-cut when necessary (page 8). Busbars fit snugly into the insulator, and the insulator snugly into the housing, but their position should be verified.

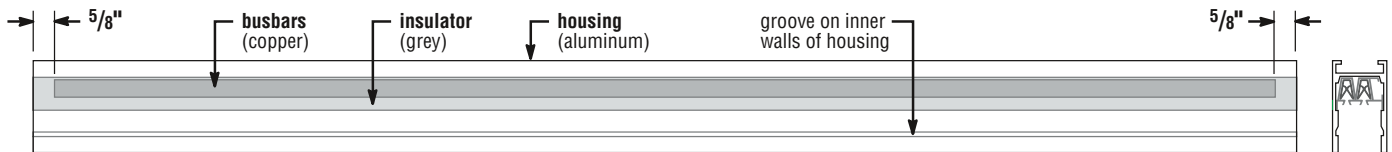

Verify that insulator is flush with housing at both ends of Joiner and that copper busbars are 5/8" back from both ends.

#### 2 • Install Bar

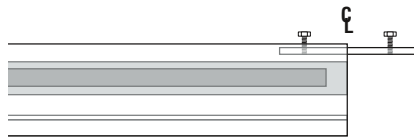

2A Slide alignment/ground bar half-way into mounting channel.

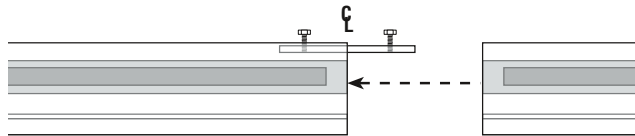

2B Add next piece to alignment/ground bar.

#### Important

To achieve polarity and correctly-made connections, ends to be joined must match internally.

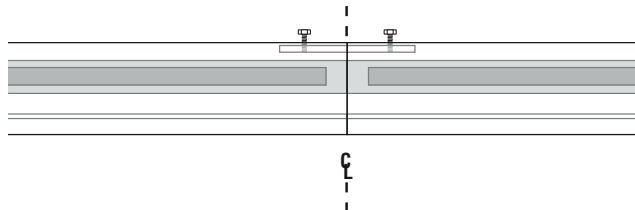
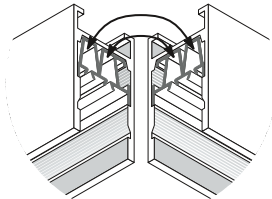

2C Center BAR across seam, and hand-tighten screws to hold.

#### 3 • Connections

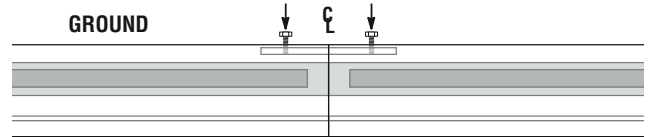

Screws on top of BAR make ground connection between pieces, as well as physically hold them together.

3A Tighten until snug, plus an additional half-turn – do **not** overtighten.

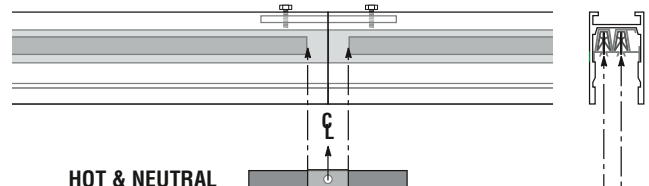

3B Use needlenose pliers to insert busbar connectors into busbars, making sure that each is **centered** inside gap at seam and pushed in **fully above** bottom of insulator.

#### 4 • Protect

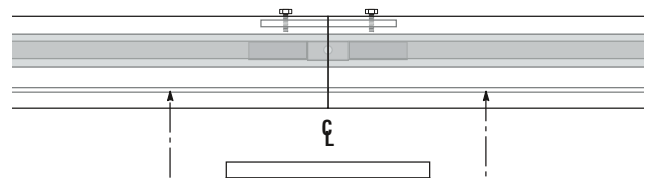

Insert protective cover, snapping edges into groove on each side of busway. Center cover at seam to protect and insulate busbar joints.

## X, T, and L Intercepts

continue power and form corners between BusRun Joiners

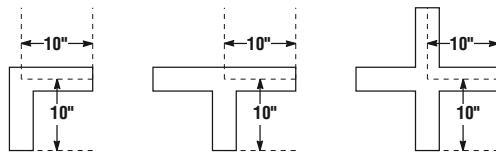

Joiners attach to X, T, and L Intercepts the same as to other Joiners, using an alignment/ground bar at every leg, and busbar connectors and protective cover only at electrical legs.

Follow the same installation procedure as for Joiners, on previous page.

The number of bars, busbar connectors and protective covers may vary from what is shown at right, depending on X, T, or L Intercept requirements.

NOTE: X, T, and L Intercepts are pre-wired at the factory for individual applications — they cannot be altered in the field. When using X, T, and L Intercepts in a grid, a drawing must be provided so proper layout can be achieved.

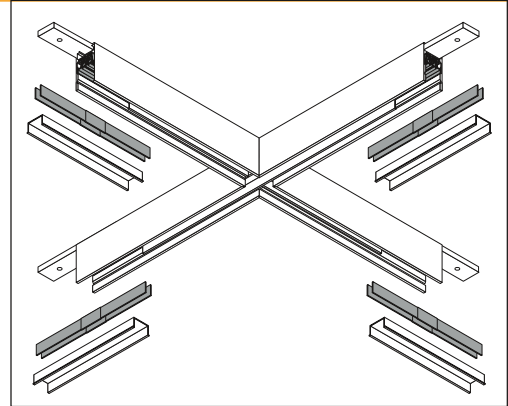

## Modular Length Joiners

Standard BusRun Joiners are available in **FULL** four, eight, and ten foot lengths. In addition, standard **REDUCED** and **SHORT** lengths allow 4, 8, and 10 foot modularity to be maintained when Starters and X, T, and L-Intercepts are factored into grids.

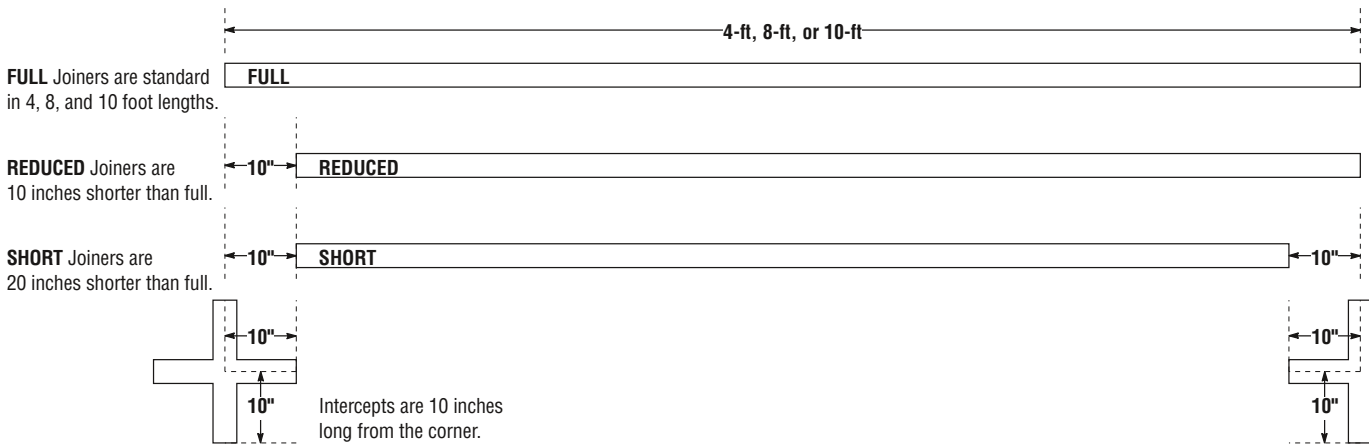

## Examples

The examples at right illustrate the usefulness of Full, Reduced, and Short Joiners in maintaining modularity.

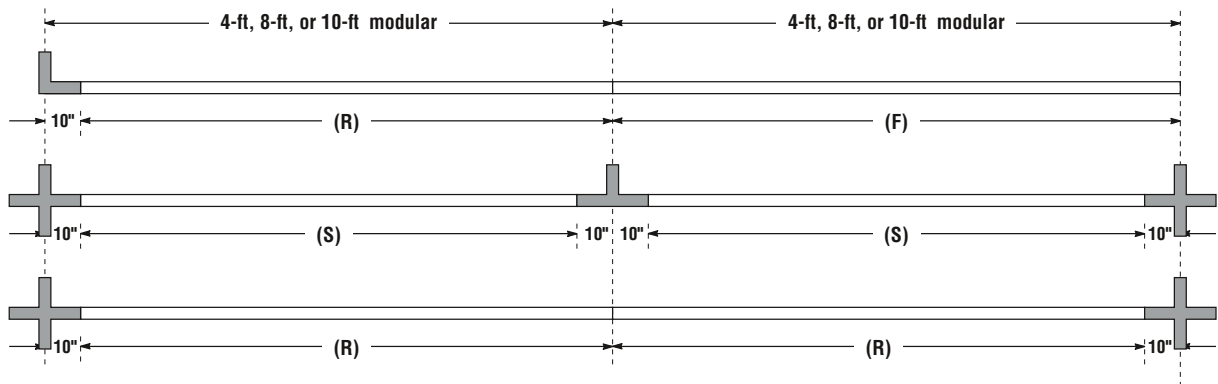

Key	Joiner type	maintains modularity:
(F)	= Full-length Joiner	between Joiners at both ends
(R)	= Reduced-length Joiner	between Intercept at one end, Joiner at other end
(S)	= Short-length Joiner	between Intercepts at both ends

details  
pages 2-4

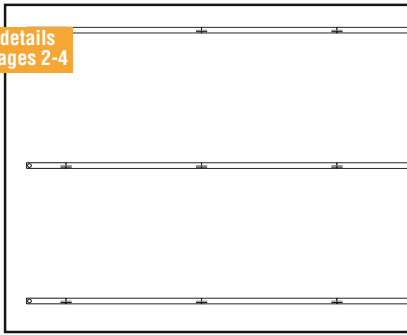

## 1 Consult Layout

- Working from planned layout, determine the number and location of feed points and mounting points.
- Feeds must comply with ratings for Starters (page 4) or Low-Voltage Ratings (supplied as separate booklet).
- Mounting points must comply with Mounting Rules (pages 2-3).

details  
pages 2-3

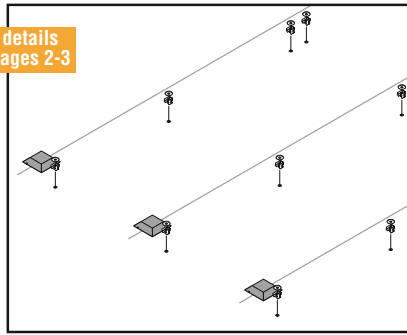

## 2 Install Mounting Hardware

- Mounting hardware is packed separately from BusRun.
- Secure Mounting Hardware to structure in compliance with Mounting information (pages 2-3) as well as any additional instructions supplied with the specified mounting hardware.

details  
page 3

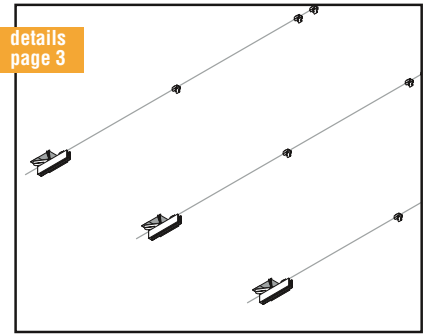

## 3 Connect Starters to Mounting Hardware

- Mount Starters to Mounting Hardware at feed points, but do not connect feed wires until later.

details  
page 5

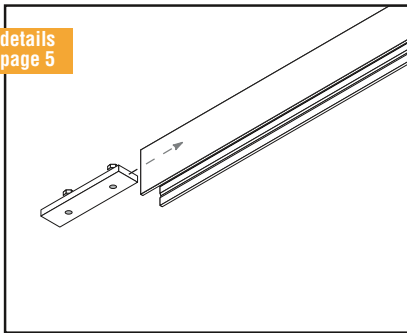

## 4 Insert Ground/Alignment Bar in Joiner

- Slide Ground/Alignment Bar onto correct end of Joiner (page 5).

details  
page 5

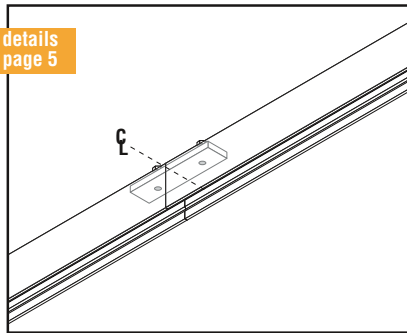

## 5 Join Pieces with Bar

- Join BusRun pieces together with Ground/Alignment Bar (page 5).

details  
page 3

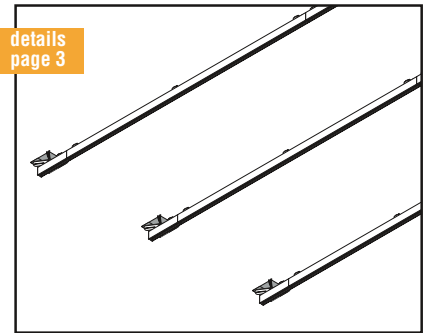

## 6 Connect Joiners to Mounting Hardware

- Mount Joiners to Mounting Hardware.

details  
pages 4-5

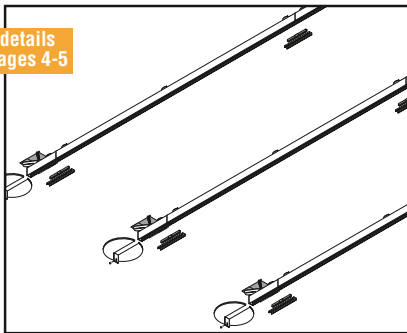

## 7 Make/Verify Electrical Connections

- Follow detailed instructions on page 5 to: Verify ground connections at Bars. Make hot and neutral busbar connections. Install protective covers at all busbar connections.
- Make feed connections to Starters (ratings, page 4).

details  
page 1

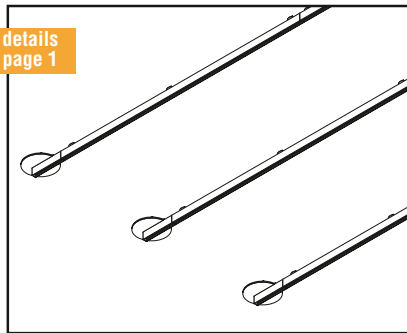

## 8 Fasten Canopy (if supplied)

- If Canopy Feed is used, fit slotted end of Canopy onto feed. Use screw supplied with canopy to attach canopy tab to hole in end of feed.
- When BusRun installation is complete, install lighting fixtures and other Listed devices, as shown on separate BusRun Plug-In Fittings instructions.

Modular Full, Reduced and Short Joiners along with X, T, and L Intercepts (page 6) eliminate most field-cutting, but sometimes it may be necessary to trim an end of run. Only BusRun Joiners can be field-cut — **Starters and Intercepts cannot be field-cut** because the busbars are not adjustable. Field-cutting any BusRun piece except a Joiner will negate its connectability to any other piece and void its warranty.

**EQUIPMENT LIST:**

- Chop saw with aluminum cutting blade OR mitre box and fine-tooth hacksaw
- Safety glasses
- De-burring tool

- 1 Mark desired field-cut length of BusRun on joiner housing.

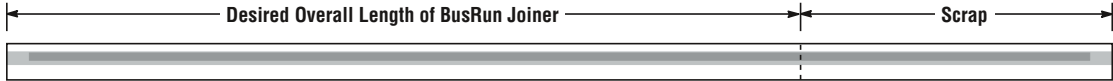
- 2 Verify that grey insulator is flush with aluminum housing at BOTH ends of Joiner.

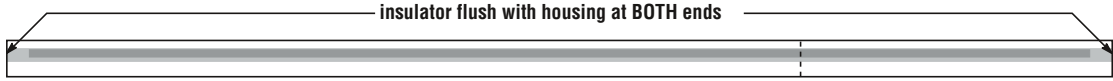
- 3 Push copper busbars into Joiner until flush with insulator and housing at SCRAP end, producing a 1 1/4" gap at opposite end.

- 4 Wear safety glasses while making a 90° cut at the marked location.

- 5 De-burr cut ends of housing, insulator, and busbars.

- 6 Push busbars back from cut end to create 5/8" gap at BOTH ends.

